

SpeedBox 3.2 for Specialized

STEP 1: Preparation for installation

A. Prepare the following tools (tools may vary depending on the type of e-bike):

1. Crown wrench
2. Socket wrench 22 mm
3. Crank puller
4. Ratchet 1/2"
5. Hex key H10
6. Hex key H8
7. Hex key H6
8. Hex key H5
9. Hex key H4
10. Hex key H3
11. Hex key H2.5

Use a torque wrench set according to the bicycle manufacturer's recommendations when tightening screws.

B. Turn off the e-bike.

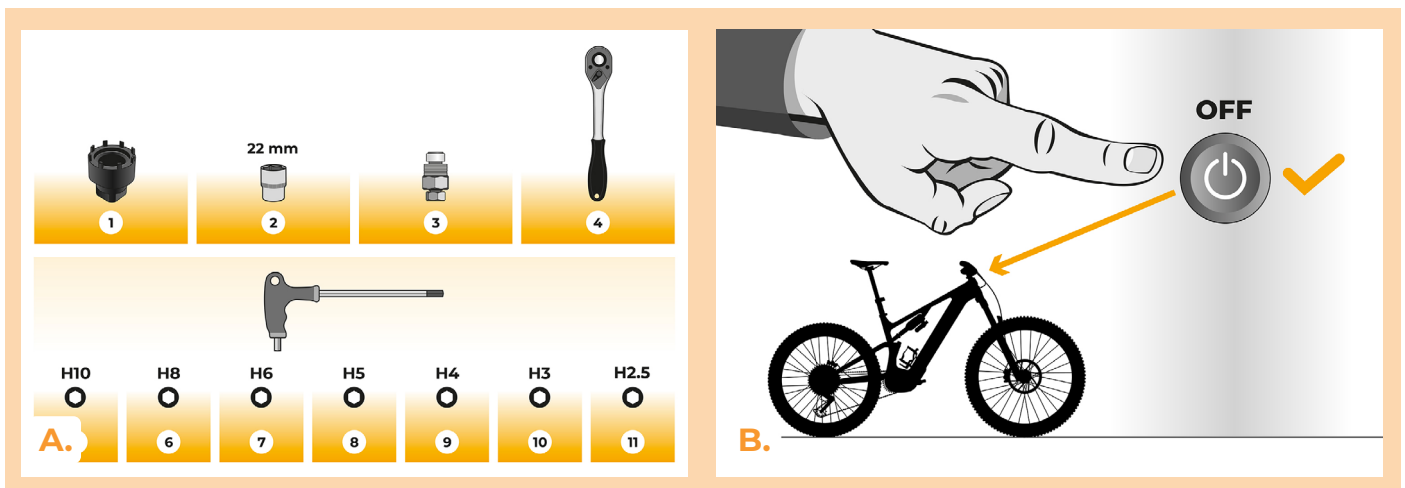

STEP 2: Removal of the battery and display from the e-bike frame

Motor cover disassembly may vary depending on the e-bike's design.

- A.** Unscrew the bolt holding the battery cover using an H6 Hex key and remove the cover.
- B.** Remove the battery from the e-bike frame.
- C.** Slide the display out of the bike frame.
- D.** Unwrap the cables from the casing to access the connectors.
- E.** Turn the bike so that the motor faces upward.

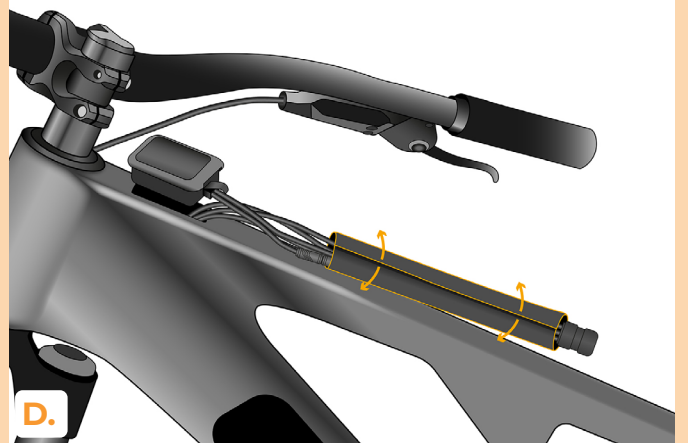
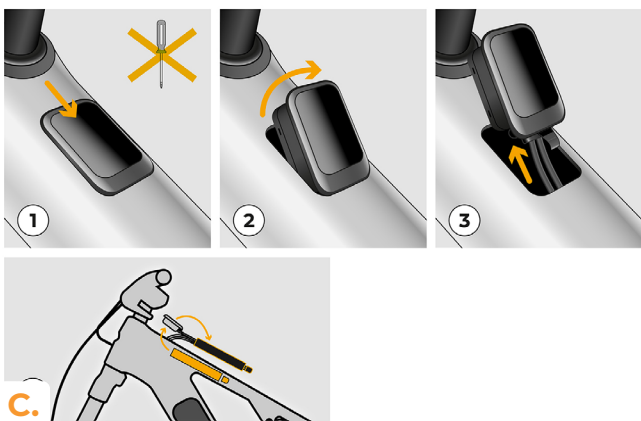
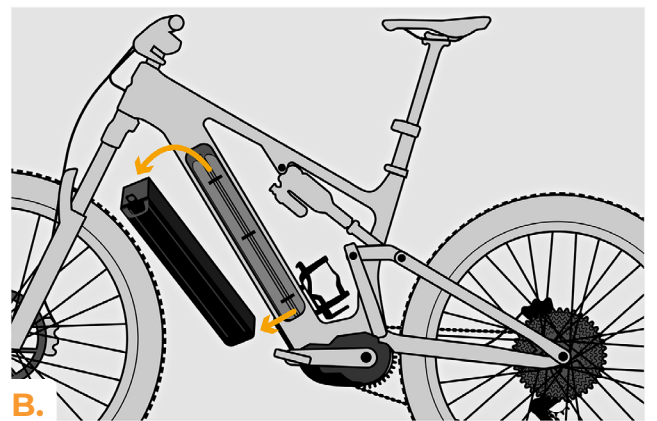
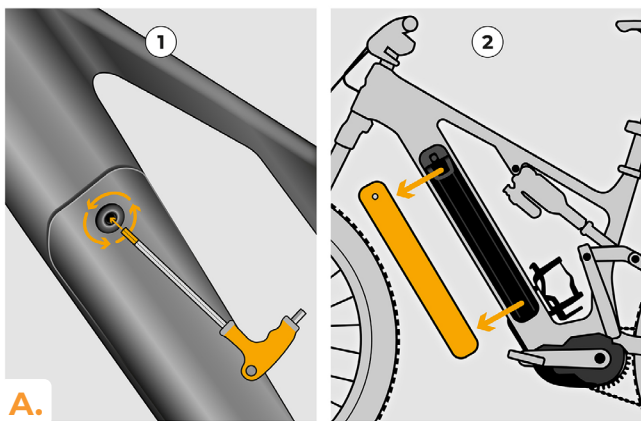

STEP 3: Removal of the cover and motor from the bike frame

- A.** Unscrew the motor cover from the e-bike frame using a Hex key H4 and remove it.
- B.** Remove both crank arms from the motor.
 1. Unscrew the cover nuts on the crank arms using a Hex key H10.
 2. Unscrew both locking bolts from the crank arms using a Hex key H8.
 3. Carefully remove the washers located under the bolts.
- C.** Use a crank puller and ratchet to loosen and remove the crank arms from the motor.
- D.** Fold the chain guide aside and remove the chain.
- E.** Using a crown wrench, remove the nut securing the chainring and take it off.
- F.** Remove the chain guide using a Hex key H4.
- G.** Unscrew three bolts on each side of the frame using a Hex key H5 to detach the motor.
- H.** Disconnect both connectors in the motor.
- I.** Remove the motor from the e-bike frame.
- J.** Unscrew the two bolts securing the battery connector between the motor and the battery using a Hex key H3.

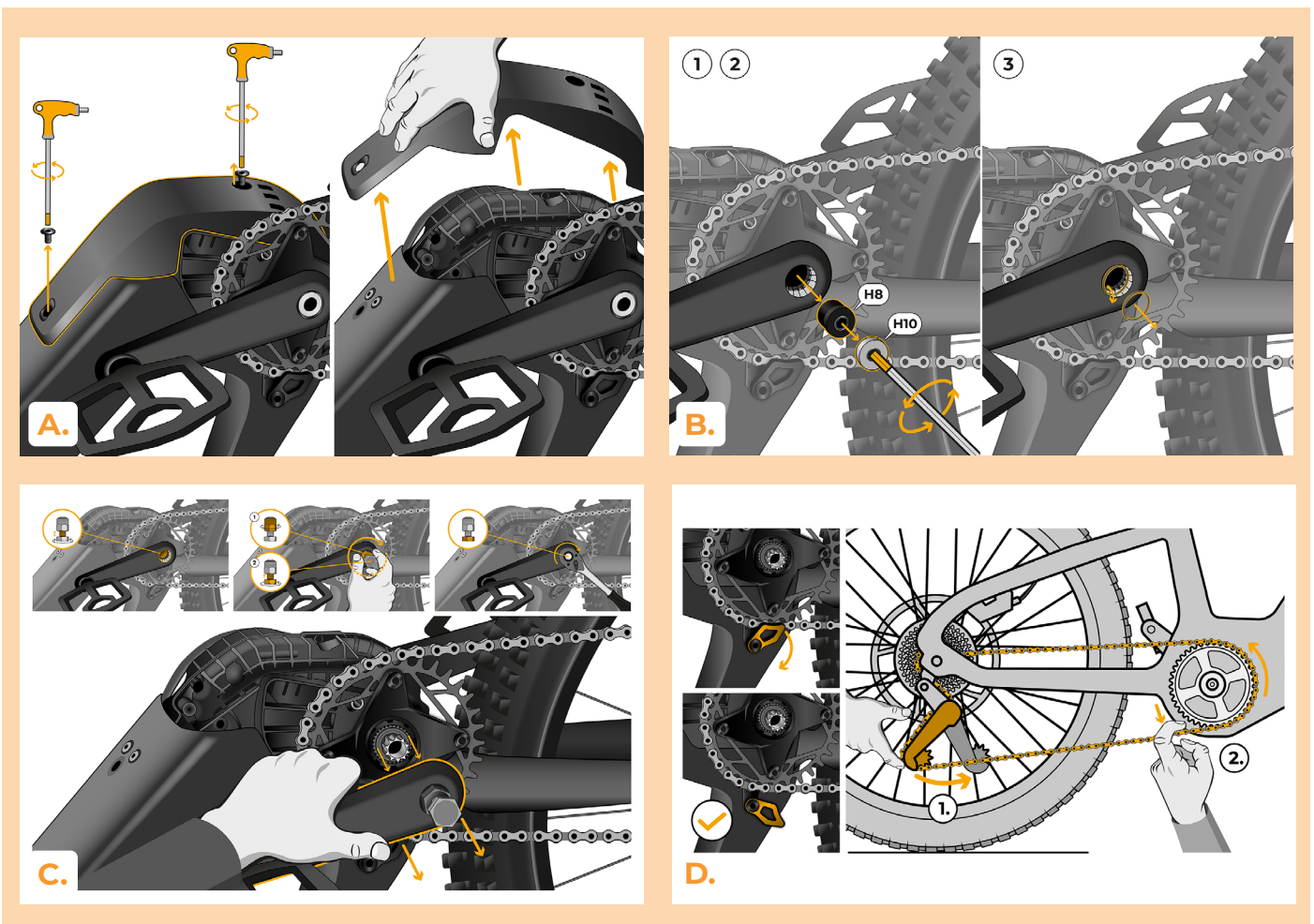

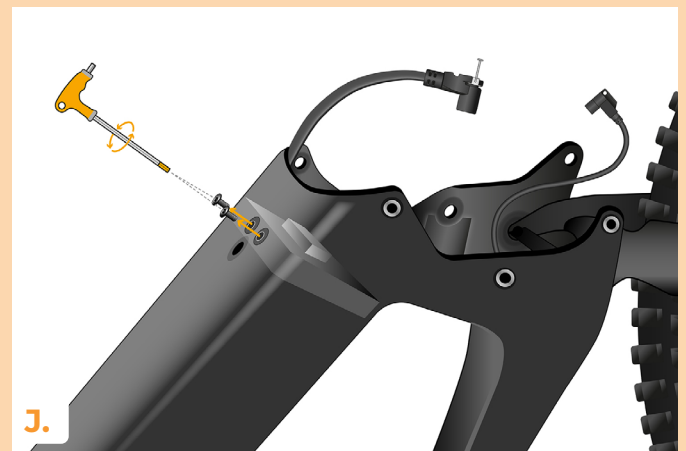
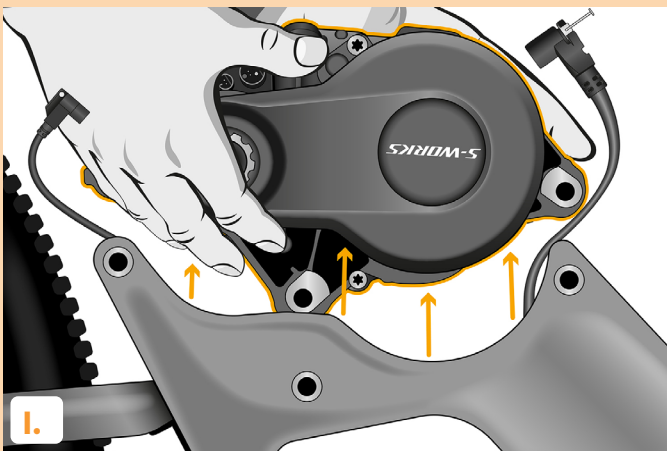
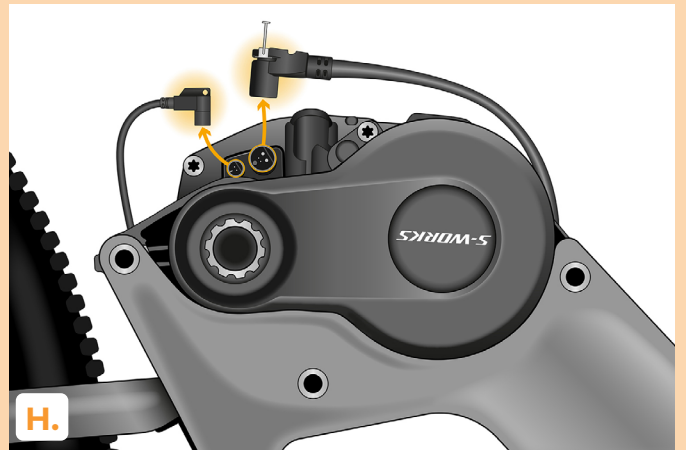
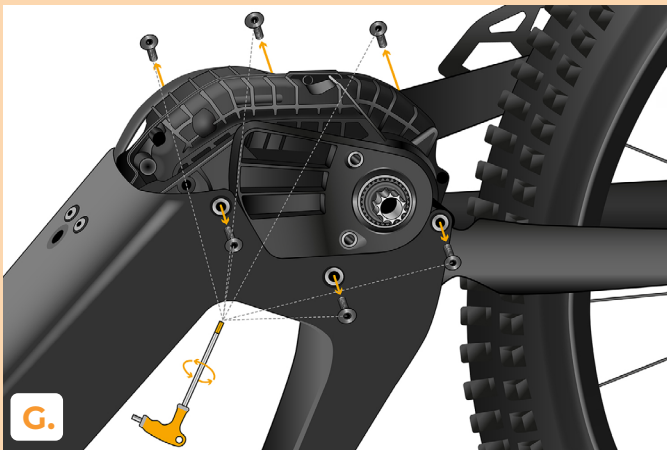
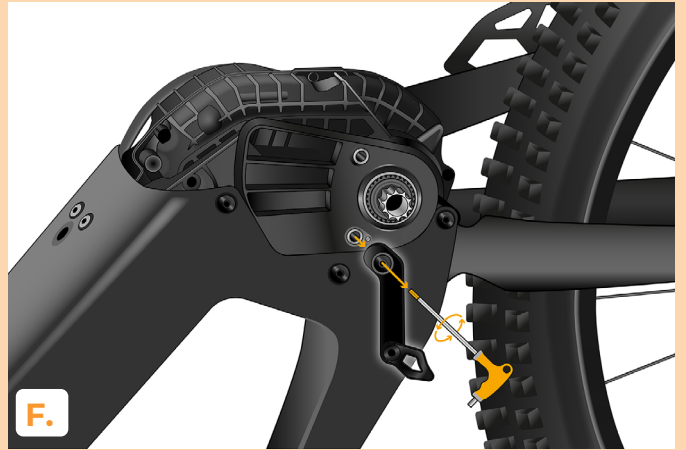
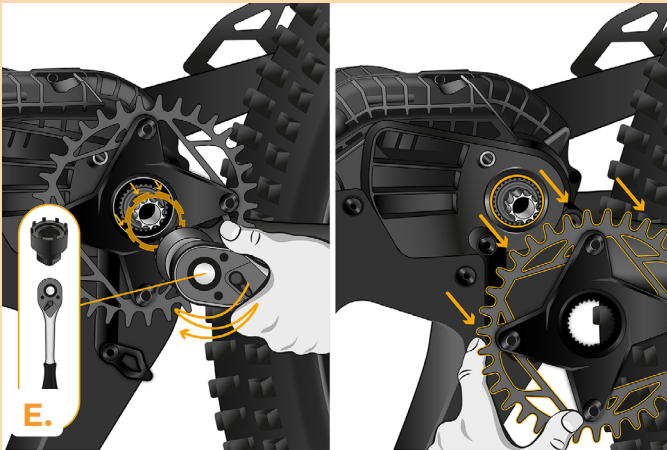

STEP 4: Installation of the SpeedBox tuning in the motor

- A.** Route the SpeedBox Tuning unit between the inner motor cover and the battery on the chainring side. Guide the unit with shorter connectors through the e-bike frame towards the display opening until the entire SpeedBox unit with the short cables emerges from this opening.
- B.** Using a Hex key H2.5, loosen the screw securing the cable clamp under the motor. Insert the SpeedBox Tuning cable under this clamp (on the side opposite the chainring) so that the connectors face the rear wheel. Lead the white cable sleeve up to the clamp. Insert the second cable from the motor (Speed Sensor) under the plastic cover on the opposite side and guide it to the end, placing it fully beneath the cover. Finally, tighten the cable clamp firmly again.
- C.** Connect the SpeedBox Tuning cables to the Speed Sensor cable, ensuring the connector locks click properly into place.
- D.** Reinstall the battery connector bracket between the motor and the battery and secure it with both screws, making sure it is correctly aligned.
- E.** Now reinstall the motor back into the frame. Ensure that the cables underneath the motor do not obstruct proper seating, and that the speed sensor and power cables follow the same routing as before removal.
- F.** Tighten the motor on each side with three bolts using a Hex key H5, and secure them with a torque wrench (the torque value is indicated on the bolts).
- G.** Finally, connect the cables to the motor, making sure all connector locks engage correctly.

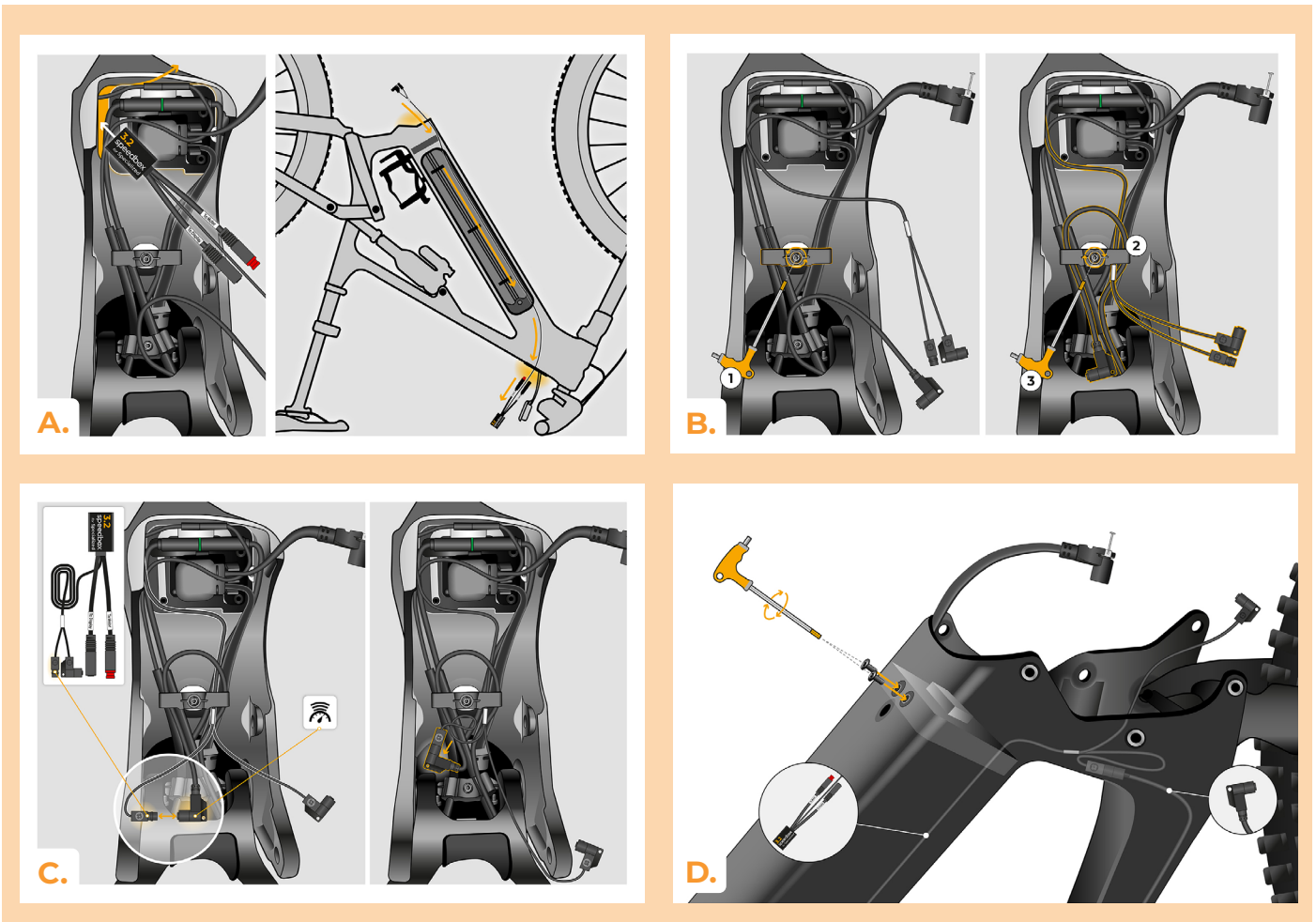

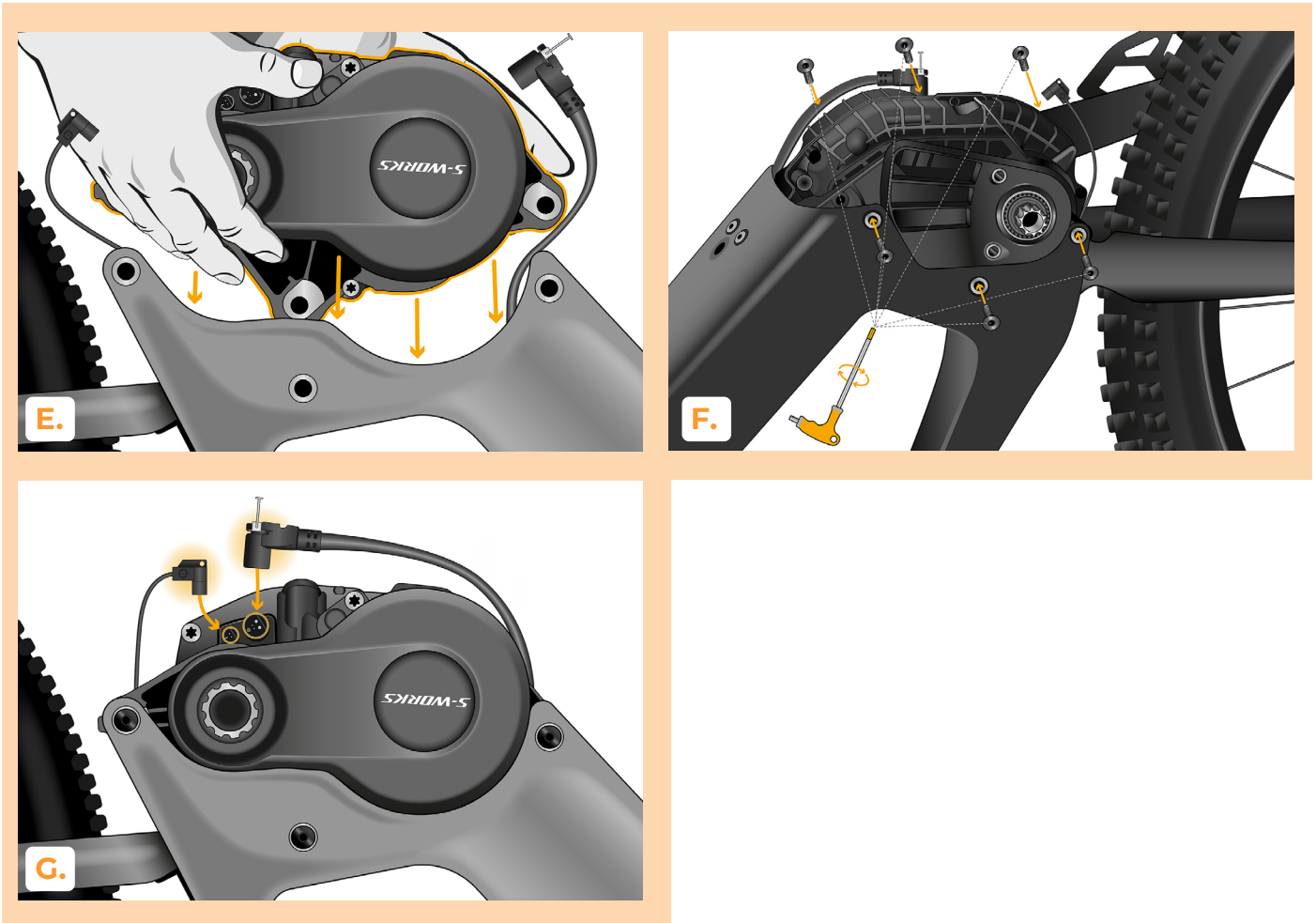

STEP 5: Completing the motor installation

- A.** Reinstall the motor cover onto the e-bike frame and secure it using a Hex key H4.
- B.** Screw the chain guide back in place using a Hex key H4.
- C.** Reinstall the crank chainring onto the motor axle and secure it with the locknut using a crown wrench. Tighten it with a torque wrench. **WARNING:** observe the specified torque values when tightening the chainring. The values are indicated on the chainring locknut.
- D.** Place the chain back onto the chainring and close the chain guide.
- E.** Reinstall both crank arms. Place the washer on the bolt and screw it in together with the locking bolt, then fit and tighten the cover nut. Repeat the same procedure for the other crank arm.
- F.** Turn the e-bike back onto its tires.

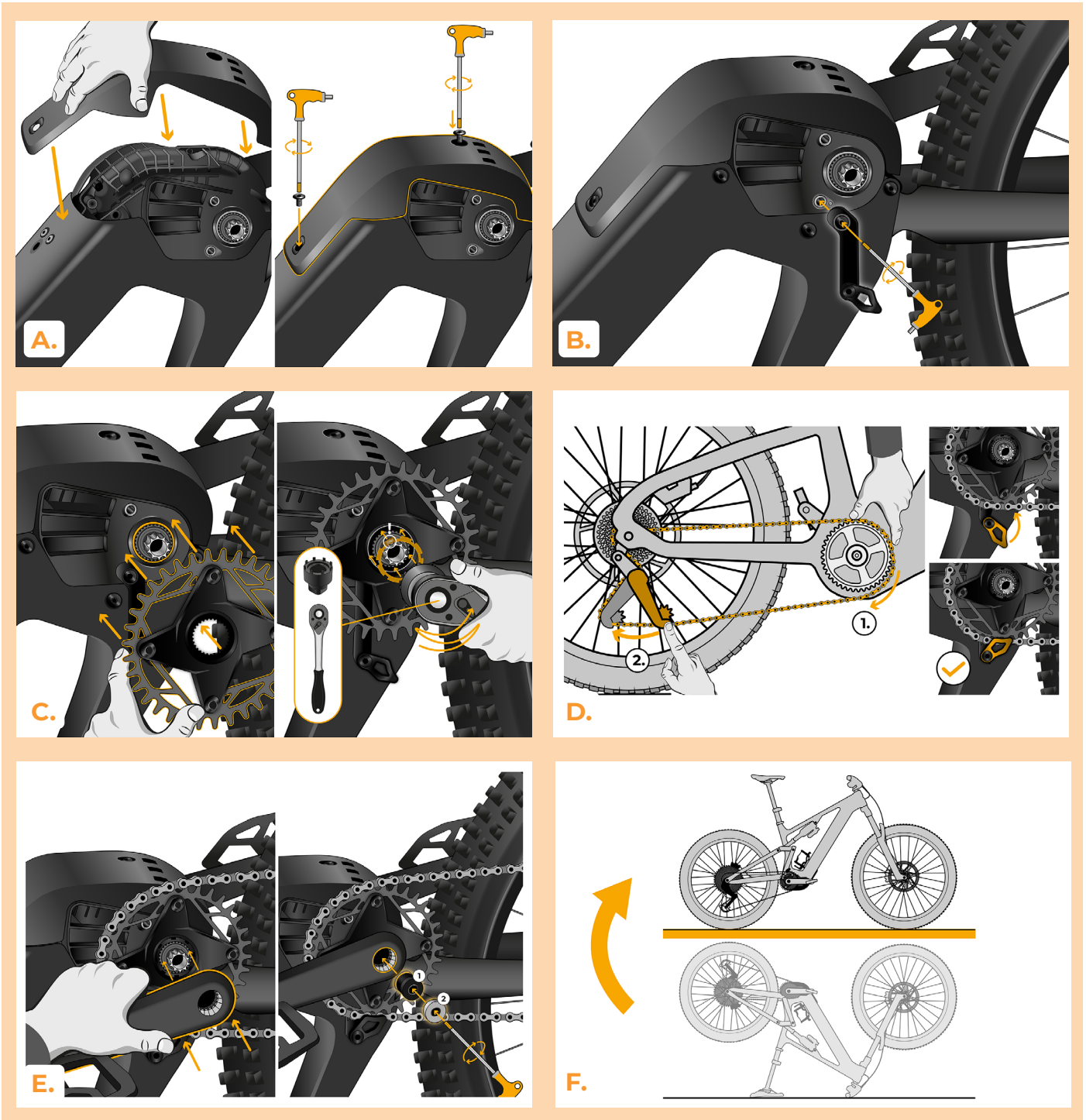

STEP 6: Installation of the SpeedBox device with display

- A.** Clip the SpeedBox Tuning cables into the free cable holders near the battery so that they do not obstruct battery installation.
- B.** Now disconnect the green-marked display connector.
- C.** Connect the disconnected connectors to the SpeedBox Tuning device.
- D.** Make sure the connector locks are properly engaged.
- E.** Place the cables and the SpeedBox device back into the protective casing.
- F.** Feed the casing through the display opening into the top frame tube.
- G.** Reinstall the display into the frame.
- H.** Reinsert the battery into the e-bike frame and secure the battery cover.

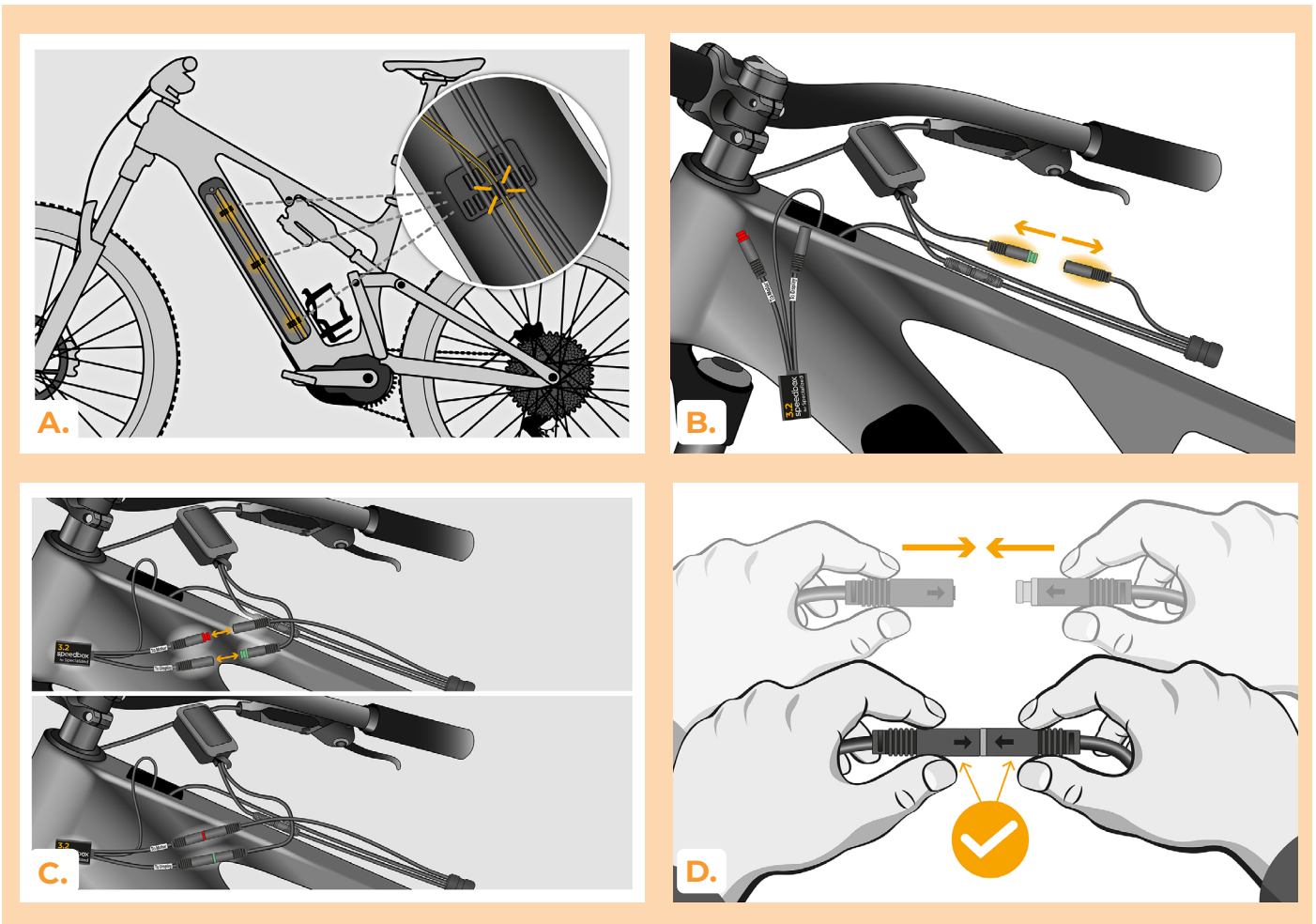

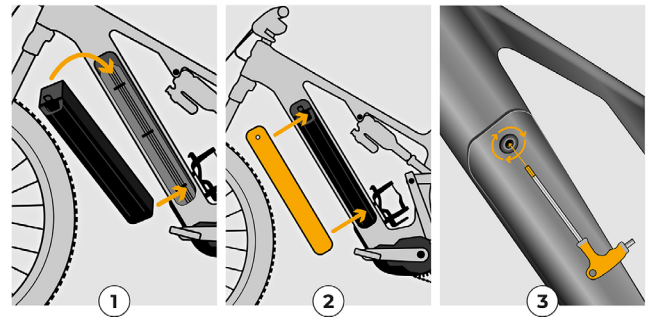
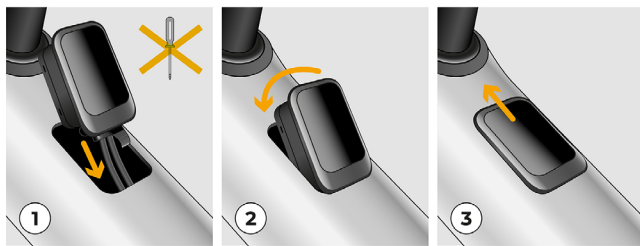
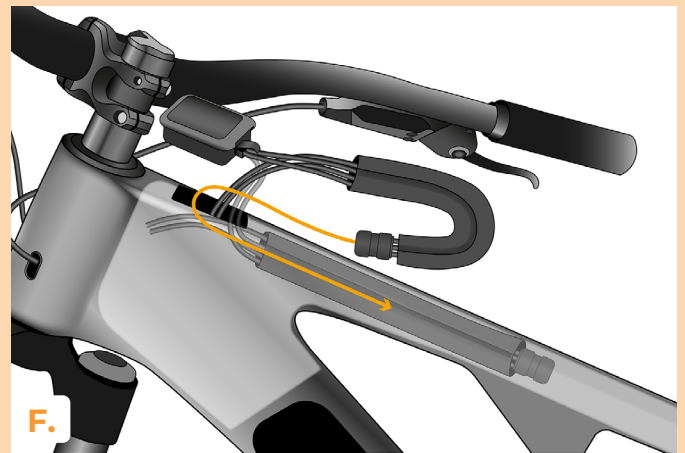
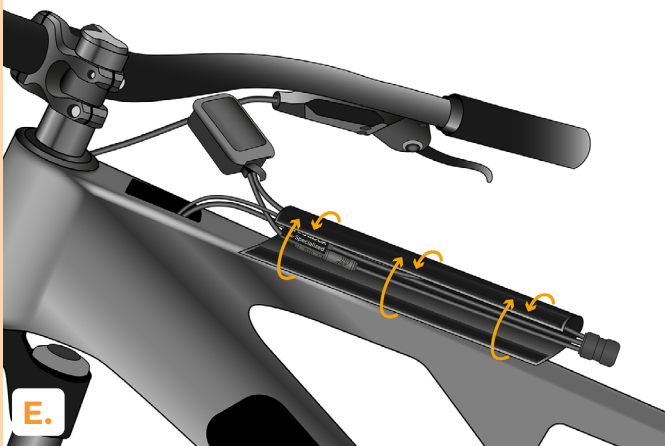

STEP 7: Tuning function check

- A.** Check the functionality of the SpeedBox Tuning device.
- B.** Activate/deactivate the SpeedBox by briefly pressing the Walk button or by changing modes with the joystick lever: ↓↑↓↑. **WARNING:** always activate/deactivate the tuning before riding, not while riding.

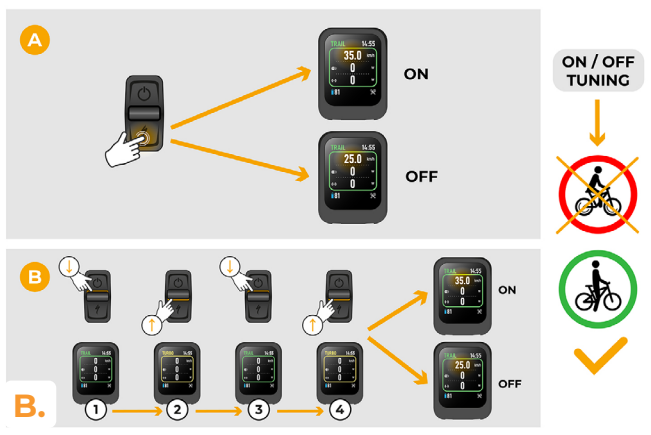
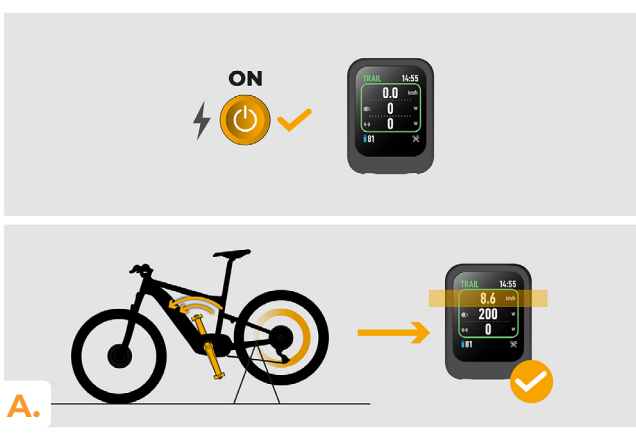

STEP 8: Setting the speed limit

- A.** Set the maximum assisted speed by changing modes with the joystick lever: ↓↓↓↑↑↑ Turbo – Trail – Auto – Eco – Auto – Trail – Turbo or Trail – Auto – Eco – Off – Eco – Auto – Trail. The current speed limit will be displayed.
- B.** Adjust the maximum assisted speed by briefly pressing the Walk button or by turning the rear wheel 360°. The last displayed limit is saved after five seconds of inactivity. Do not adjust the maximum speed while riding!

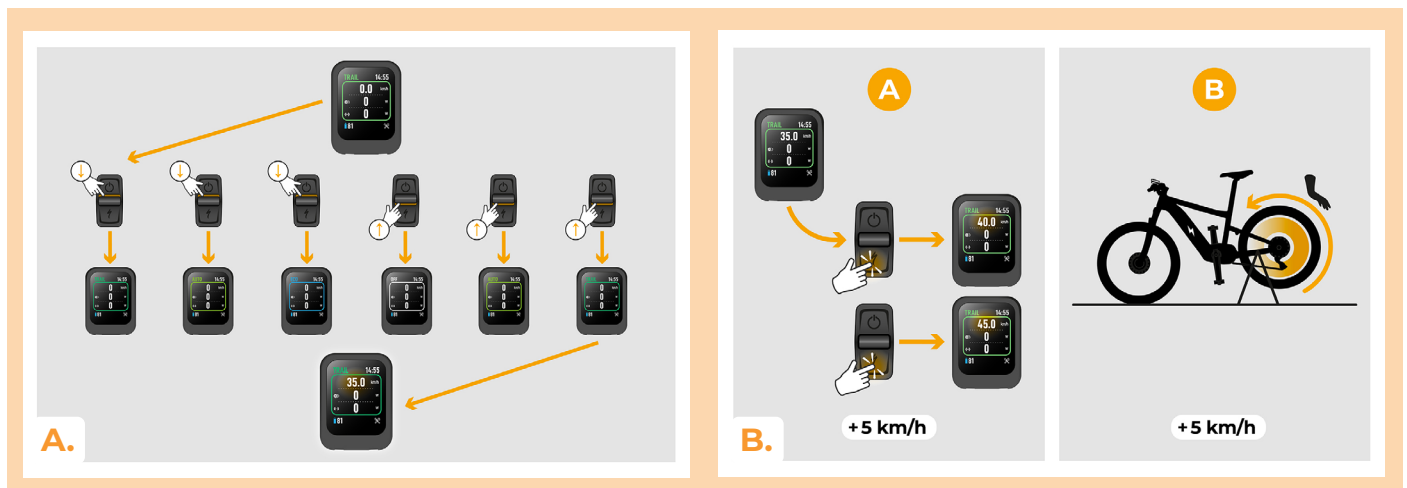



www.speedbox-tuning.com

Ebike Electronic s.r.o.

Rybna 716/24 | 110 00 Praha 1 | Czech Republic | ID: 05553555 | VAT: CZ05553555

