

SpeedBox 1.4 for Bosch

STEP 1: Preparation for installation

We recommend using bike repair stand during tuning installation.

- A.** Prepare the following tools
(tools may vary depending on the type of e-bike)
1. Cutting Pliers
 2. Hex key H3
 3. Torx screwdriver T40
 4. Cross-head screwdriver PH2
- B.** Check the contents of the package according to the picture.
- C.** Turn off the e-bike.

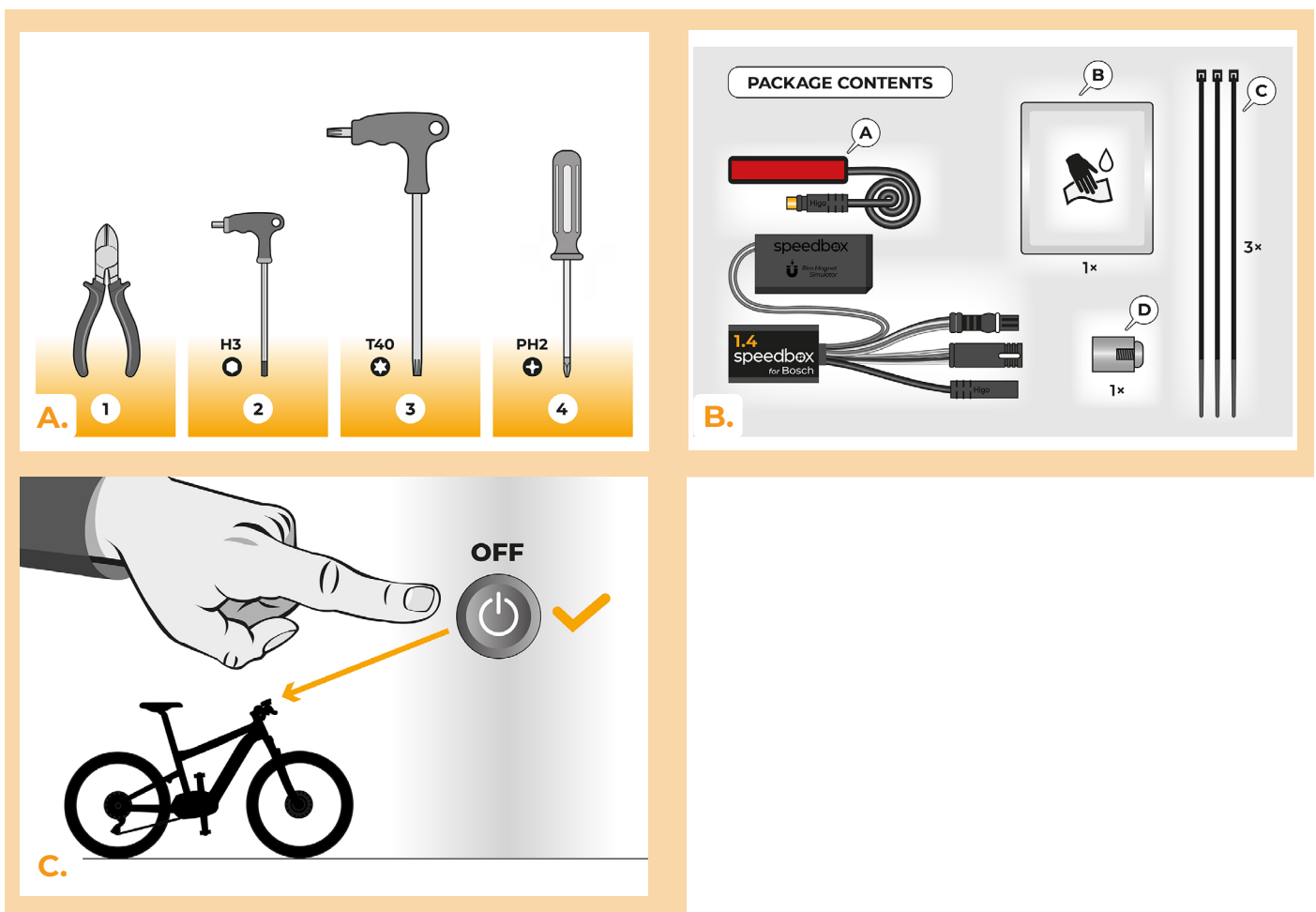

STEP 2: Rim Magnet removal and installation of the speed sensor

- A.** Remove the original Rim Magnet from the rear wheel valve. Keep it for the reinstallation (step 13).
- B.** Clean the inner side of the chainstay with a wet wipe (B).
- C.** Using double-sided tape, attach the speed sensor cable (A) to the cleaned inner side of the chainstay. The other end of the cable with the connector should point towards the motor.
- D.** Fix the speed sensor (A) firmly with two plastic tightening tapes (C). Trim off any overhanging remnants of the tape with side cutting pliers.
- E.** Using the Phillips screwdriver PH2, attach the magnet (D) to one of the spokes of the rear wheel. Place the magnet with the smooth side facing the end of the speed sensor.
- F.** Check the position of the speed sensor and the magnet relative to each other.
- G.** Secure the speed sensor with a plastic tightening tape (C) to the inner side of the chainstay, closer to the motor, to prevent any unwanted contact of the cable with the rotating rear wheel. Trim off any overhanging remnants of the tape with side cutting pliers.

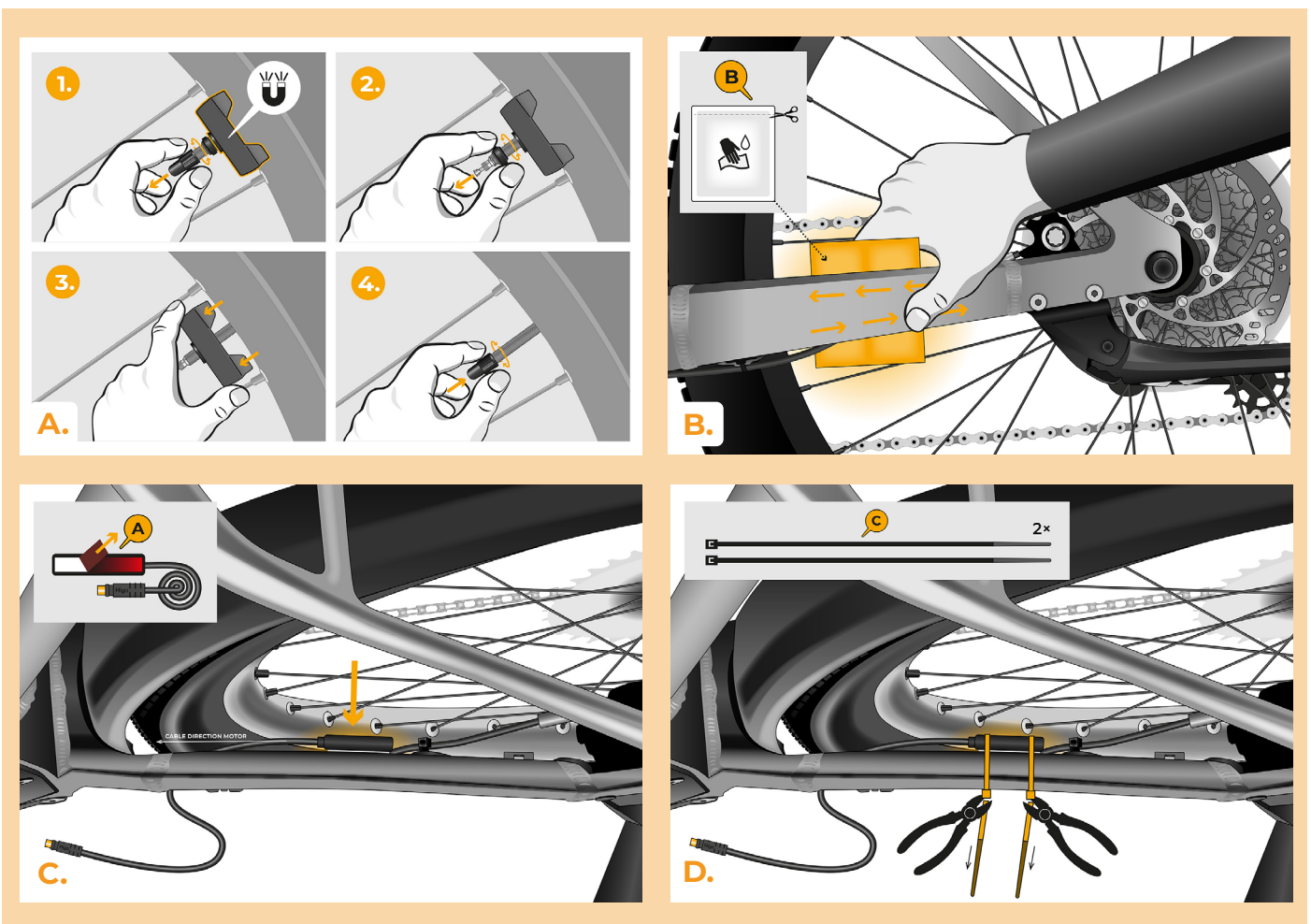

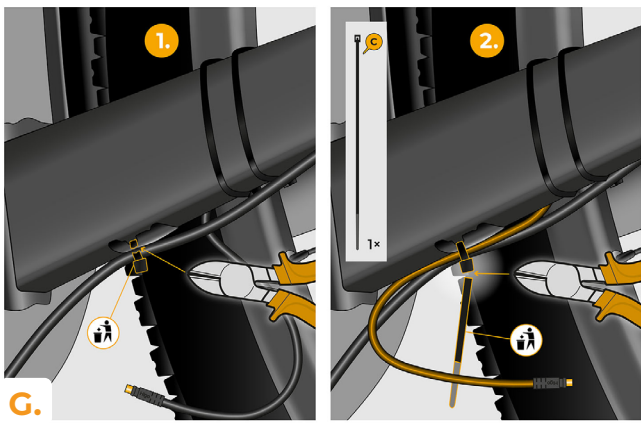
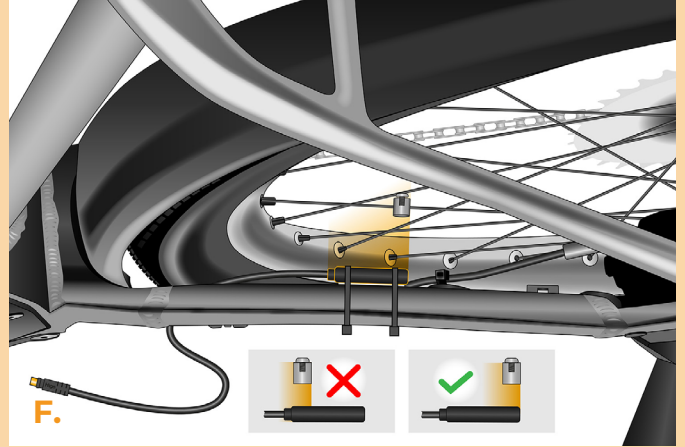
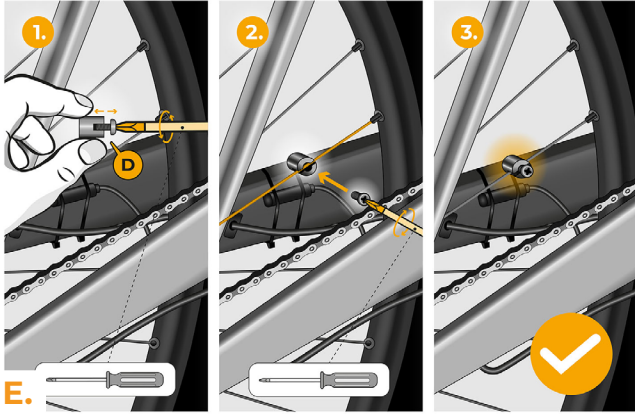

STEP 3: Disassembly of the motor and motor cover from the bike frame

The process of removing the motor cover may differ depending on the e-bike design.

- A.** Remove the chain.
- B.** Use the H3 Hex key to unscrew the motor cover.
- C.** Remove the motor cover.
- D.** Use the T40 Torx screwdriver to loosen the two screws that hold the motor in the bike frame.
- E.** Hold the motor from below with your hand to prevent it from falling out of the frame. Completely remove both screws.
- F.** Carefully pull the motor out of the e-bike frame to access the motor connectors.

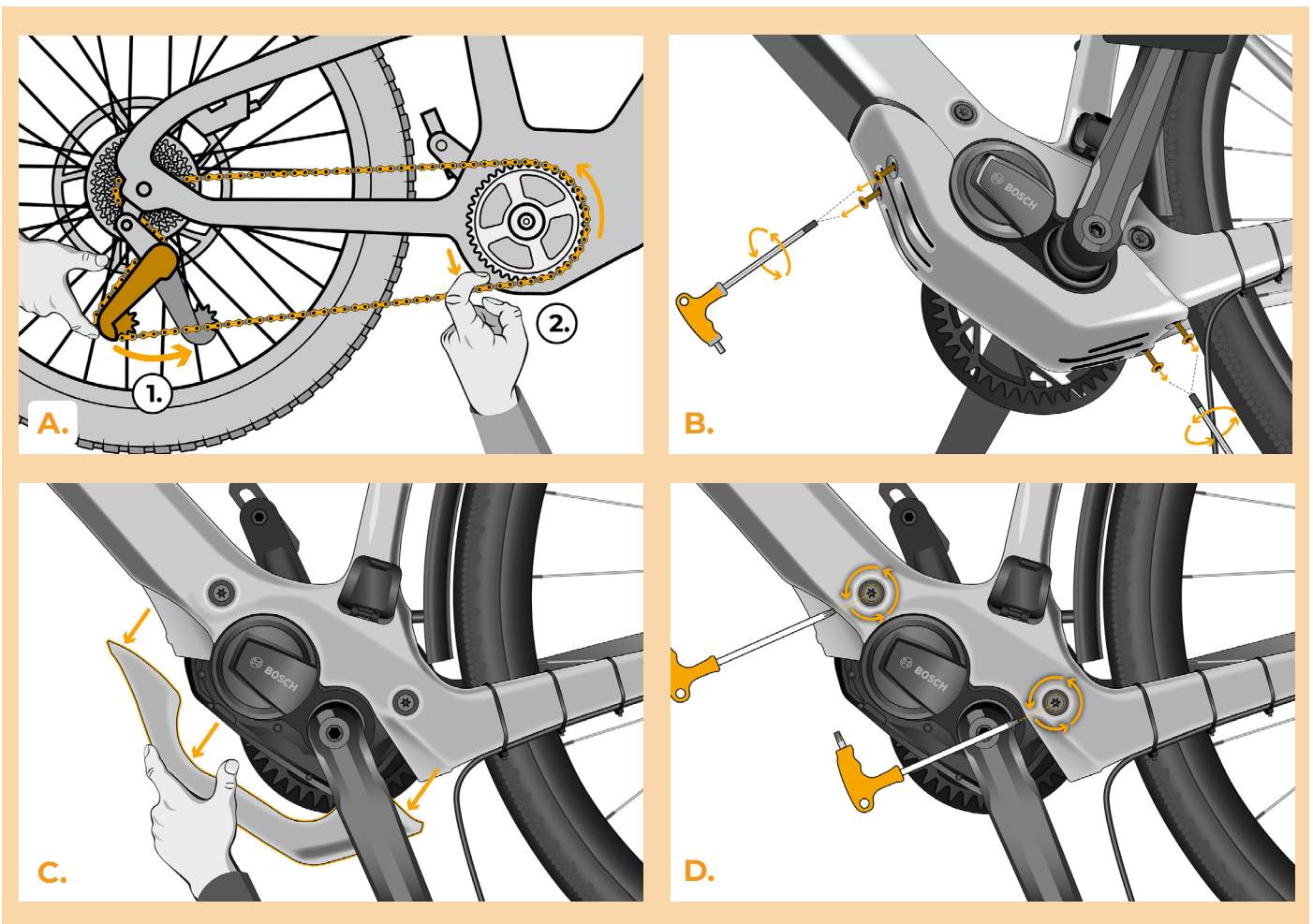

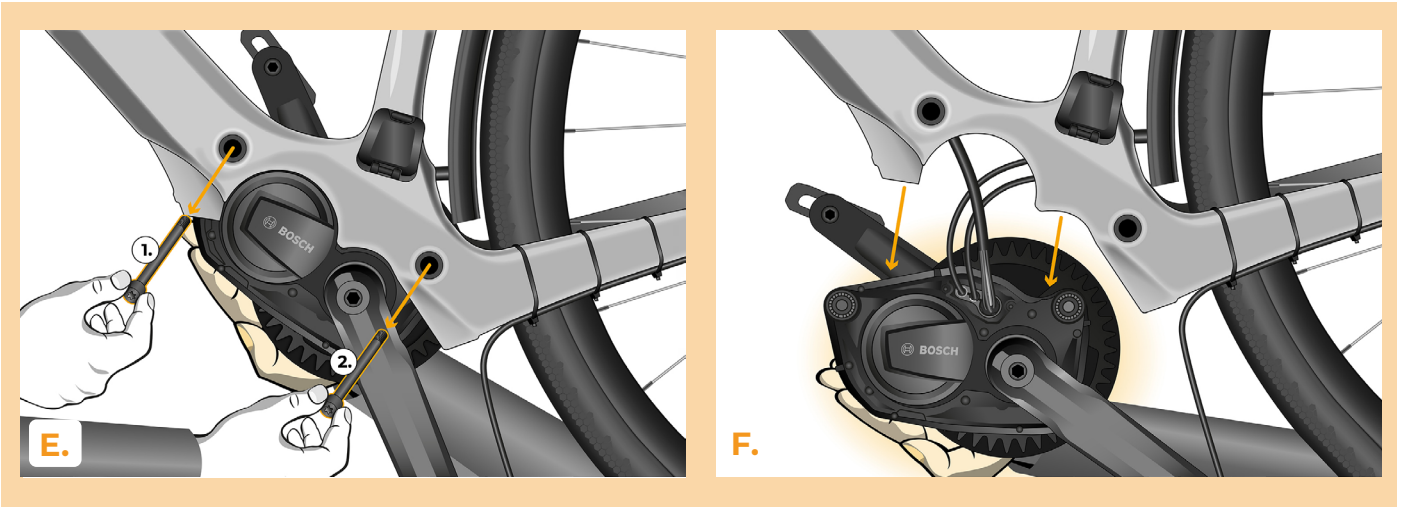

STEP 4: Disconnecting the connectors from the motor

- A.** Disconnect all cables from the motor, including the power cable from the battery.

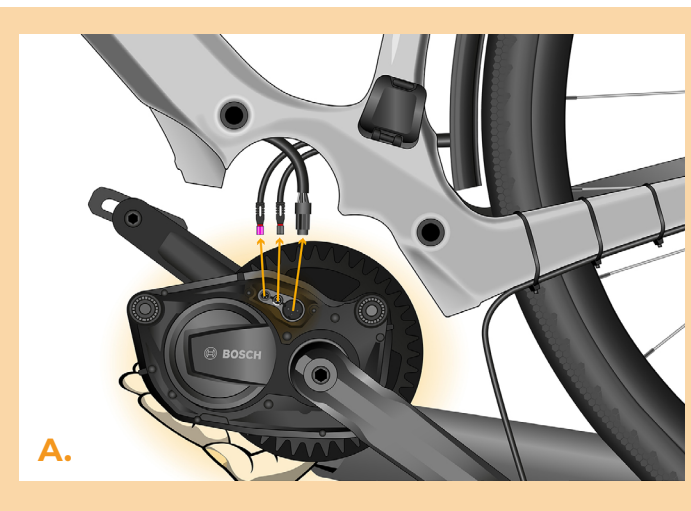

STEP 5: Attaching the Rim Magnet Simulator to the motor

- A. Remove the protective backing from the double-sided adhesive tape on the Rim Magnet Simulator.
- B. Attach the Rim Magnet Simulator to the designated spot on the motor using the double-sided tape.

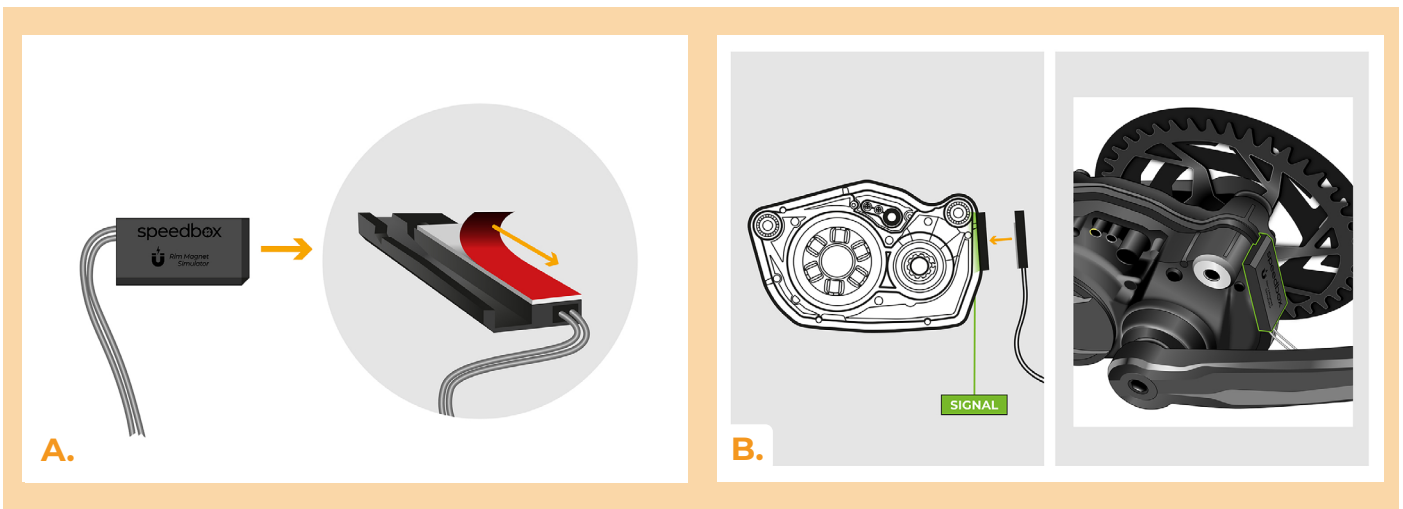

STEP 6: SpeedBox tuning installation

- A.** Connect the SpeedBox Tuning cable to the motor, replacing the original display cable. Then, plug the display cable into the largest connector on the SpeedBox Tuning device. Connect the speed sensor cable. Finally, reconnect the remaining cables to their original connectors.
- B.** Make sure that the locks on the connector are seated properly.
- C.** Check the correct wiring as shown in the figure.

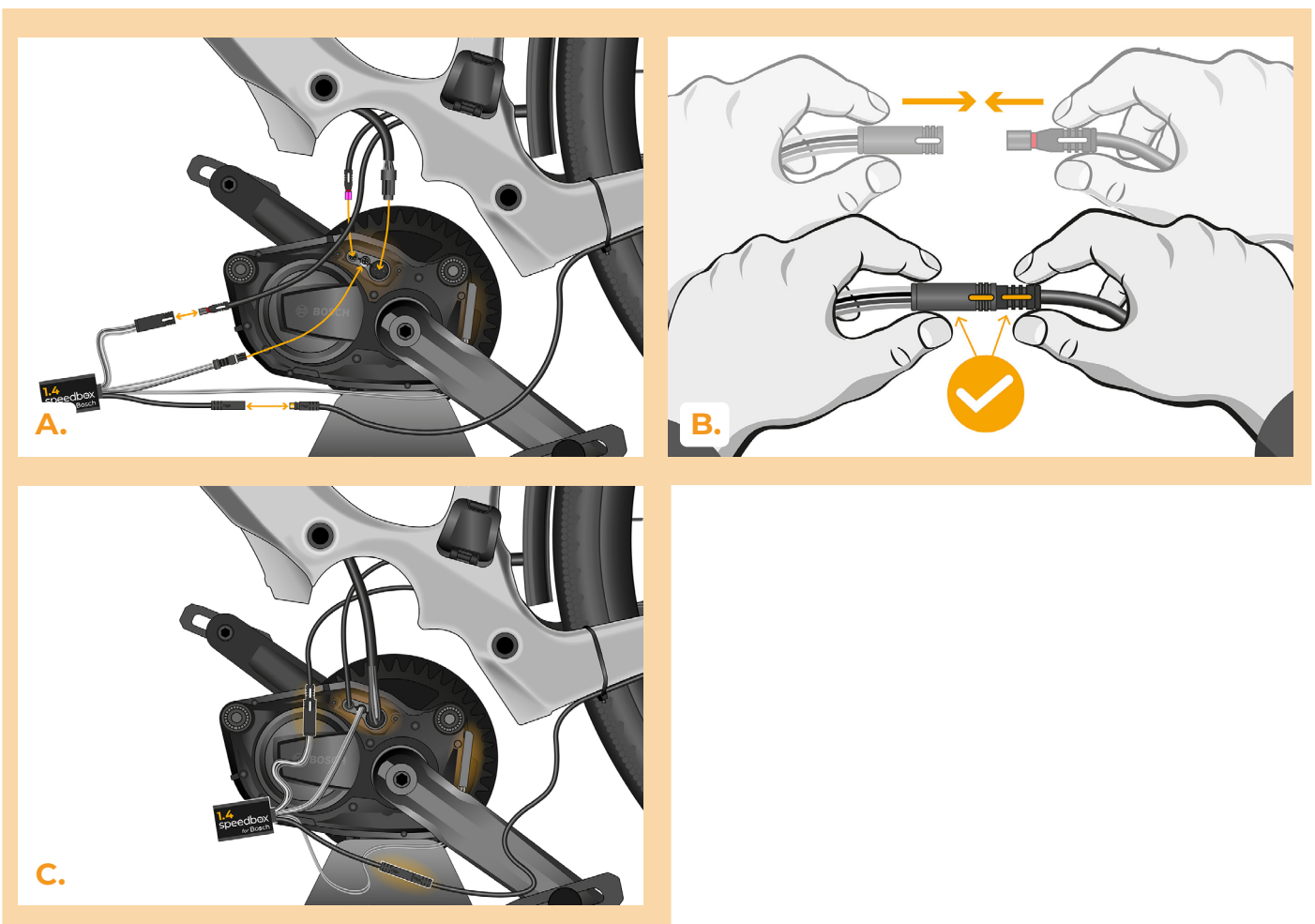

STEP 7: Reinstalling the motor into the e-bike frame and attaching the motor cover

- A.** Reinstall the motor with the Rim Magnet Simulator into the e-bike frame. Place the SpeedBox Tuning device with the motor cables back into the free space near the connectors.
- B.** Insert both screws holding the motor back into the bike frame.
- C.** Screw in both screws holding the motor using the T40 Torx screwdriver.
- D.** Reinstall the chain onto the chainring.
- E.** Check the functionality of the SpeedBox Tuning device.
- F.** Pull the speed sensor cable under the motor cover and put the cover back in place.
- G.** Screw the cover back on using the H3 Hex key.

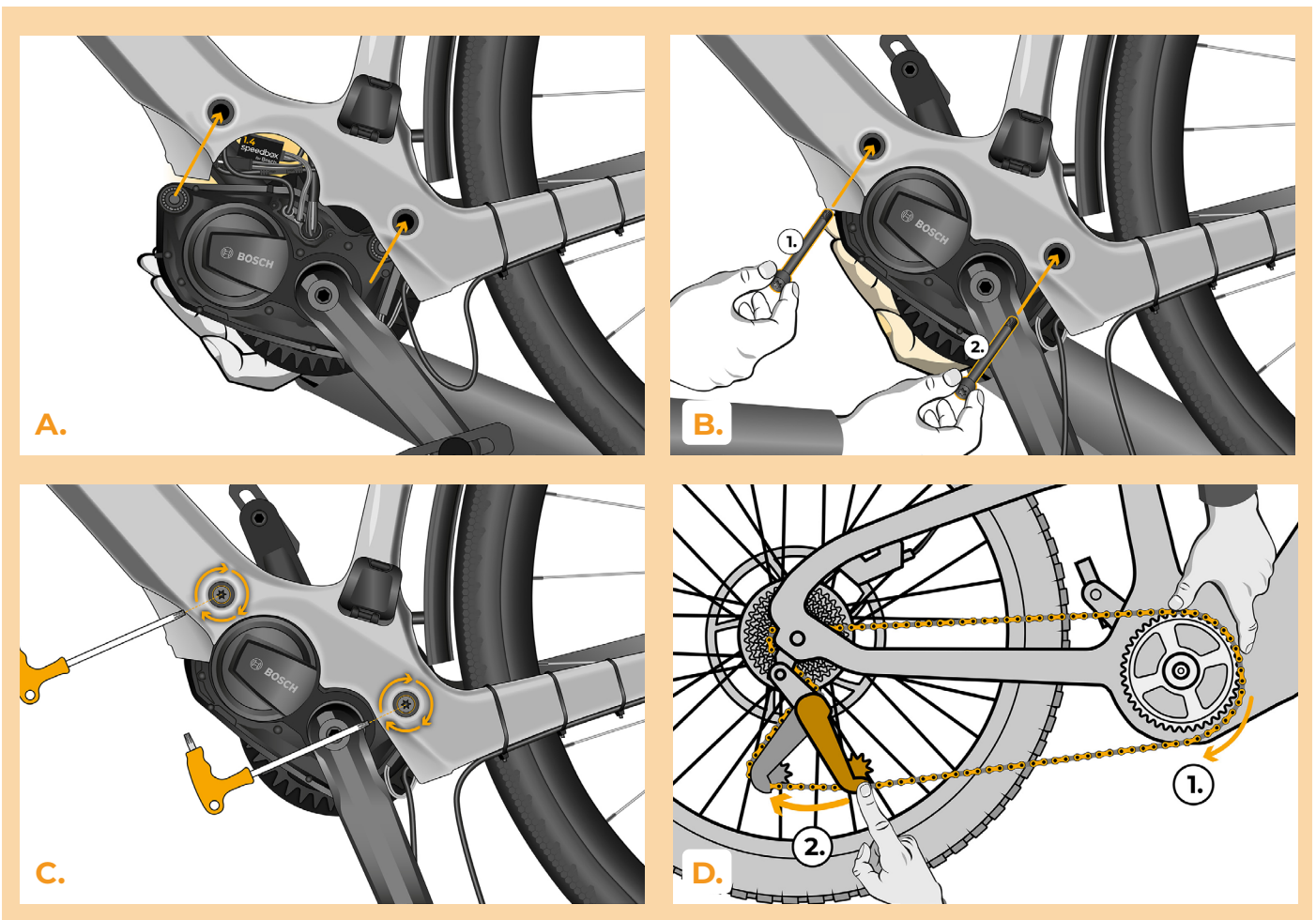

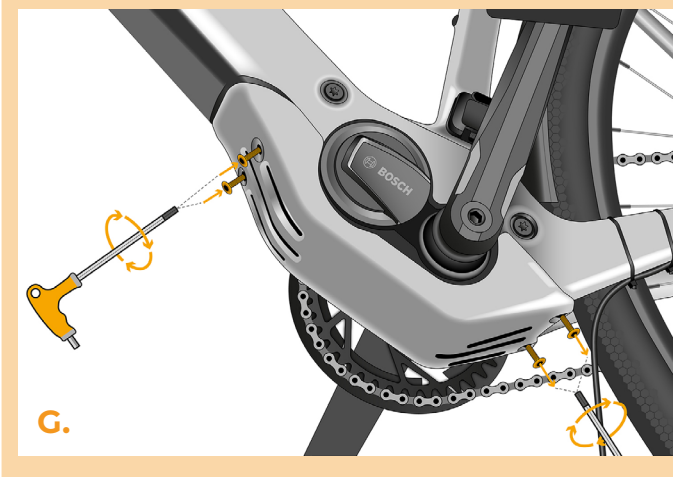
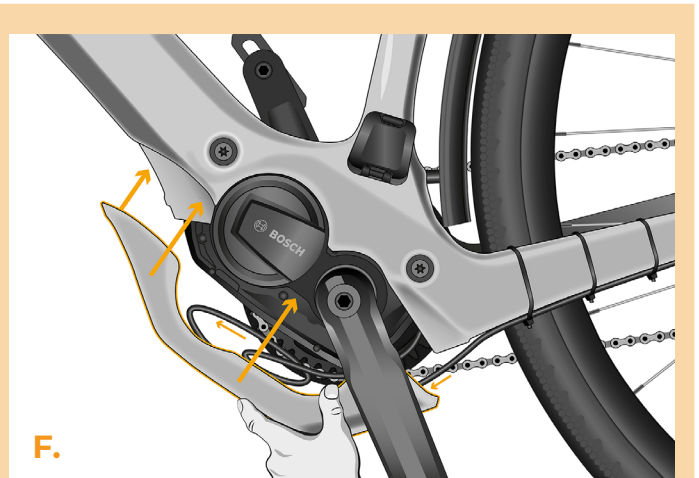
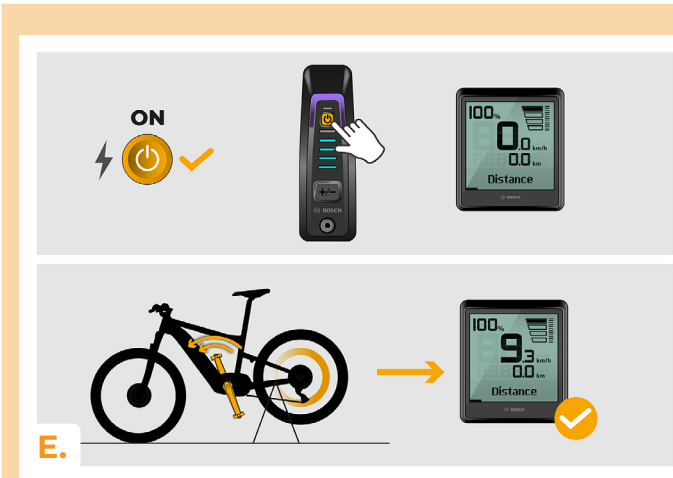

STEP 8: Tuning function check

- A. Turn the e-bike on.
- B. **Note:** This step may not apply to all types of displays. When activating for the first time, go to the display settings and check the wheel circumference: "Settings" > "My eBike" > "Wheel circumference". Then return to the home screen.
- C. Activate/deactivate tuning by brief activation of the WALK function or by switching between two assistance modes twice (- + - +). The value of 3.5 or 2.5 indicating the maximum speed in km/h will be displayed. Warning: Activate/deactivate the tuning before the ride (when the e-bike is standing still), not during riding.

A. Turn the e-bike on. The diagram shows a power button icon with a checkmark, an arrow pointing to the e-bike, and a close-up of the display showing '100%' battery and '0.0 km/h'.

B. Check the wheel circumference. Step 1: Home screen (86% TURBO 0.0 km/h) → Settings menu (9x) → Settings screen (86% TURBO 09:21 Settings). Step 2: Settings screen (Back My eBike Information) → Wheel circum. 208 mm Components → City eBike screen (Active Reset) with a checkmark.

C. Activate/deactivate tuning. **A:** Walk assist button (9) → ON (3.5 km/h) / OFF (2.5 km/h). **B:** Assistance mode buttons (- + - +) → ON (3.5 km/h) / OFF (2.5 km/h). A legend indicates 'ON / OFF TUNING' with a red 'no riding' symbol for ON and a green 'riding' symbol for OFF.

STEP 9: Setting the speed limit

- A.** You can set the maximum speed limit by changing modes from TURBO to eMTB - TOUR+ - ECO - TOUR+ - EMTB - TURBO (--- + +). An actual speed limit will be displayed after that.
- B.** The maximum speed can be changed by activating/deactivating the WALK assist function (in this case by pressing „-“ and „+“) or by turning the rear wheel 360°. The last displayed limit will be saved after 15 seconds of inactivity.
- C.** To prevent tuning detection on your e-bike, it is necessary to leave the e-bike on after finishing the ride until a value of 0.0 km/h is displayed.

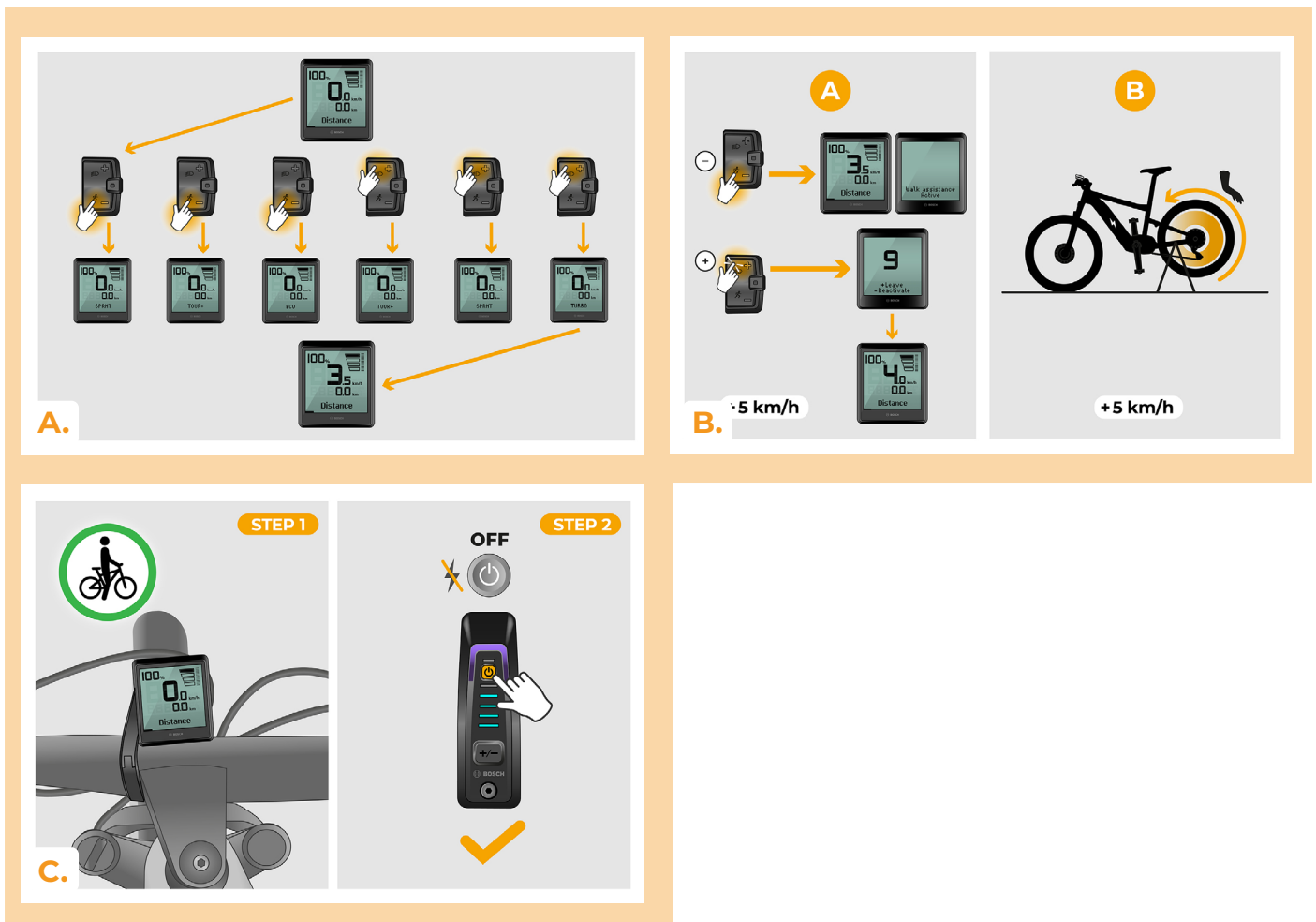

STEP 10: Deactivation and reassembly of Rim Magnet on the wheel valve

- A.** In case you want to reinstall the original Rim Magnet, first deactivate the SpeedBox by switching the modes from TURBO to eMTB – TOUR – ECO – TOUR – ECO – OFF (---+--). The display will show a speed of 12.0 km/h. Turn off the e-bike and return the original Rim Magnet to the rear wheel valve. Then turn on the e-bike and take a short ride. While riding, change gears until the real speed is shown on the display.
- B.** To reactivate SpeedBox, uninstall the Rim Magnet and then switch the modes again from TURBO to eMTB – TOUR – ECO – TOUR – ECO – OFF (---+--). The display will show a speed of 11.0 km/h which indicates that SpeedBox is activated again.

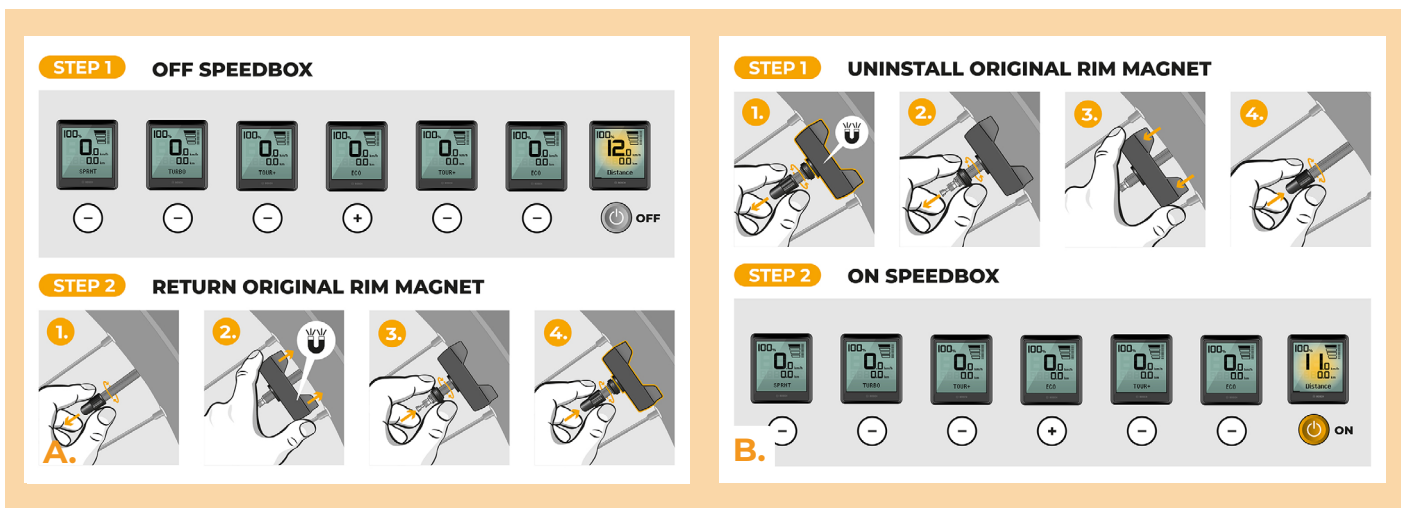

www.speedbox-tuning.com

Ebike Electronic s.r.o.

Rybna 716/24 | 110 00 Praha 1 | Czech Republic | ID: 05553555 | VAT: CZ05553555

